

Original Operating Manual

FB-UTV-1.5m-Plough



Version 1 1/2022

Content

Table of contents	Page	Section
1.1 About this manual.....	3	1.1
2 Safety.....	4	2
Intended use.....	4	2.1
Qualification of personnel.....	4 - 5	2.2
Safe working area and Hazard area.....	5	2.3
Prior to commencing work.....	5	2.4
Whilst operating the machine.....	5 - 6	2.5
Leaving the machine unattended.....	6	2.6
Attaching or detaching the machine.....	6	2.7
Electrical system and equipment.....	6	2.8
General safety instructions.....	7	2.9
Special safety instructions.....	7	2.10
3 Assembly.....	8	3
Fitting the bracket to the vehicle.....	8	3.2
Wiring the vehicle.....	8	3.3
4 Installation.....	9	4
Preparation of the snow plough.....	9	4.1
Attaching the snow plough on the vehicle.....	9	4.2
Removal of the snow plough.....	9 - 10	4.3
Adjustments on the snow blade.....	10 - 11	4.4
5 Operation.....	12	5
Operation.....	12	5.1
6 Maintenance.....	13	6
7 Electrical Connections.....	13	7
8 Troubleshooting.....	14	8
9 Parts diagram.....	15 -16	9
10 Technical Data.....	17	10
Declaration of Conformity.....	18	

1.1 About this operating manual

Dear customer!

Thank you for purchasing this attachment, we appreciate your trust.
Prior to using this attachment for the first time, read this operating manual carefully and conscientiously all the way through.

Keep this operating manual where it is easily accessible. This will enable you to refer to important information and handling instructions as needed.

Listings with bullet points are marked as follows:

- Text
- Text
- Text . . .

Handling instructions are marked in the sequence in which they should be executed, as follows:

1. Text
2. Text
3. Text . . .

This implement is subject to change in the interest of technical progress. All information, illustrations, and technical specifications represent the latest status at the time this manual was published. The manufacturer reserves the right to make changes at any time in the interest of technical progress.

2. Safety

Guidelines and instructions with which you must comply, are summarized in this section.

Personnel who mount, operate and maintain this attachment, must have read and understood this operating manual.

It is important to note that not all possibilities can be covered within this manual. The manual assumes that the operator has a general awareness for Health and Safety to have been appointed an operator in the first place. This machine has been designed, so far as is reasonably practical, so that it will not endanger the safety of the operator or anyone else if the machine is used and maintained according to the instructions stated in this manual which have been compiled following research and experience of the manufacturers. In order to minimise the risk of accidents please consider the following information

2.1 Intended use

The snow blade is an attachment for winter service and is used for clearing snow from roads, paths, and other areas.

All other uses are excluded.

Non-intended use causes:

- Danger of injury to the operator or third parties
- Damage to the tractor and the implements
- Environmental damage

Use going beyond that described is not considered as intended. Therefore the manufacturer is not responsible for any resulting damage or harm and the operator alone is responsible for the risk.

- Compliance with and adherence to the operating, maintenance and repair as prescribed by the manufacturer in this manual must be considered essential elements of intended use.
- The machine may only be operated, repaired and serviced by persons familiar with the machine, this manual and all relevant safety features and dangers.
- The relevant rules for the prevention of accidents as well as other safety relevant rules according to the health and safety at work act must be considered as part of the operating procedure.
- The manufacturer is not liable for any accidents or damage resulting from modifications or alterations carried out on the machine without the express written permission of the manufacturer.

2.2 Qualification of personnel

Only personnel 18 years of age or older, or instructed personnel should install, operate, and maintain the snow blade. The operator must have read and understood this operating manual.

This machine may be subject to regulations when used on the public highway.

Before starting operating this machine you should be familiar with all controls and their functions. Familiarisation should not be carried out during operation. It is too late!

- Beware of rotating parts—keep safe distance.
- Beware of trailing machines and machines with inertia. Ensure they stop completely before making any adjustments.
- Standing in the danger area of the machine is forbidden!
- Operators are advised to wear suitable clothing that is close fitting with stout footwear (safety boots). Loose fitted clothes or casual footwear increase risk of accidents.
- Do not leave the engine running in an enclosed area.
- Keep machine clean to reduce the risk of fire
- Be aware that the handling, steering and braking ability of power units/machines may be affected by different attachments, when loading/unloading and when using on gradients
- Unauthorised alterations, which compromise the reliability of the machine are prohibited!
- Always inspect the machine prior to use.

2.3 Safe working area and Hazard Area

- The operator is responsible for operating the unit in the work area.
- The operator is responsible for third parties in the work area.
- Third parties must not be in the working area.
- Look out for any children or animals close to the work area. Ensure you have adequate visibility.
- Prior to starting work, survey the area for objects that could cause a hazard and remove them.
- When operating in confined areas always allow sufficient safety margin against the border to avoid damage to the machine.
- When operating machinery in public areas or in the immediate vicinity, use suitable, prominent signage to draw the public's attention to the hazards of the working area.

2.4 Prior to commencing work

- Before attempting to operate the machine, please familiarise yourself with all the equipment, controls and their function. Ensure all safety devices are properly fitted and in the protective position.
- Learn how to stop and park the machine quickly and safely in the event of an emergency.

2.5 Whilst Operating the Machine

- Never leave the operator console/position while driving.
- Never adjust the steering wheel while engine is running
- Never leave the equipment unsupervised, when the engine is running.
- Never leave the vehicle whilst the engine is running.
- Do not transport goods or passengers on the machine.
- Always switch off the vehicle, let it come to rest and disable a machine before attempting to clear any type of blockage or making any adjustment.

- Only leave the operating position once the vehicle has come to a complete rest and is safely parked.
- If a fault with the plough or vehicle is detected, stop immediately and rectify before further use.
- Consider carefully before attempting to operate any machine on any inclined slope.
- Where possible, always traverse a slope, not up and down.
- Wet and icy weather can increase the hazard of operating any machine on a slope.

2.6 Leaving the Machine Unattended

- Always chock the wheels or apply parking brake (where fitted), when leaving a vehicle.
- Always disable a machine when not in use by removing the ignition key or removing the spark plug lead.
- Try to minimise the possibility of unauthorised use.
- Turn off the controller.
- Never leave a machine before it has been switched off and come to a complete rest.

2.7 Attaching or detaching the machine

- Before attempting to attach or detach any implement, ensure the vehicle is off and handbrake is on.
- Always use appropriate tools, gloves and other suitable safety clothing.
- When attaching and detaching the implement always ensure that all parts of the equipment are stable and suitably supported at all times.
- Always apply the parking brake (where fitted) or use chocks to prevent machines from rolling away.
- The snow plough is heavy. Always plan in advance how to change the attachment using the easiest and safest method. This will reduce the possibility of injury.
- After attaching the implement, ensure all pins are secured and safety devices are enabled and operational. After attaching implements, visually inspect the complete unit for any possible fouling areas in and out of work conditions.

2.8 Electrical System and Equipment

- When working on an electrical system with a battery, always disconnect the earth terminal from the battery. If working on the plough isolate this from the vehicle battery by unplugging it.
- When connecting a battery, always connect the positive terminal before the negative terminal.
- Beware of battery gases. They are explosive.
- Never allow sparks or open flames near a battery.
- Caution when handling battery and/or acid. Very Caustic! Wear eye protection and gloves in addition to any other suitable safety clothing.
- The positive terminal must always be protected by a complete battery cover or terminal cover to prevent accidental contact with negative or ground.
- Persons with cardiac pacemakers should be especially cautious whilst touching the electrical or engine ignition system. Serious injury could occur! Do not touch.

2.9 General safety instructions

General safety instructions are explained in this section. These safety instructions are used in the subsequent sections. In addition to the safety aspect, you will save money and work time if you follow these safety instructions



Danger!

**Severe injury to the operator or third parties can occur.
Follow the safety instructions.**

Attention!

**Minor injury to the operator or third parties can occur. The vehicle, the plough, or the environment can be damaged.
Comply with the safety instruction.**



Note!

Important, helpful tips or information for the operator. Read this note. It facilitates your work.

Attention!

**Injuries can occur due to improper operation. The attachment can be damaged.
Read the operating manual all the way through.**

Comply with the safety instructions.

Attention!

**Danger of crushing due to moving parts.
Never reach into the crushing hazard danger zone, if parts are still moving or can move.
Comply with the instructions in the operating manual.**

2.10 Special safety instructions



Attention!

Prior to use, read and comply with the operating manual and the safety instructions.



Attention!

Prior to performing maintenance and repair tasks, turn off the engine and remove the key.

Assembly

3. Assembly

3.2 Fitting the bracket to the vehicle

Follow individual bracket instructions to fit onto your vehicle. These instructions are supplied with the bracket.

3.3 Wiring the vehicle, (*before wiring the vehicle check that the cables will reach from the plough to your intended connection place on the vehicle*)

1. Run the winch controller and 12v plug into the cab
2. Plug the 12v plug into the cigarette/12v power socket

Installation

4. Installation



Attention!

Before beginning the installation fully read operating manual and safety instructions.

4.1 Preparations on the snow blade

Before attempting to install the plough onto the vehicle ensure that the blade is angled straight, the attachment pin is removed from the 50mm spigot.

The vehicle and plough must both be on a flat level surface.

4.2 Attaching the snow plough on the vehicle

Align the plough in front of the vehicle, lift the headstock using the lift handle and slide the spigot into the receiver on the vehicle. Secure the spigot with the locking pin.

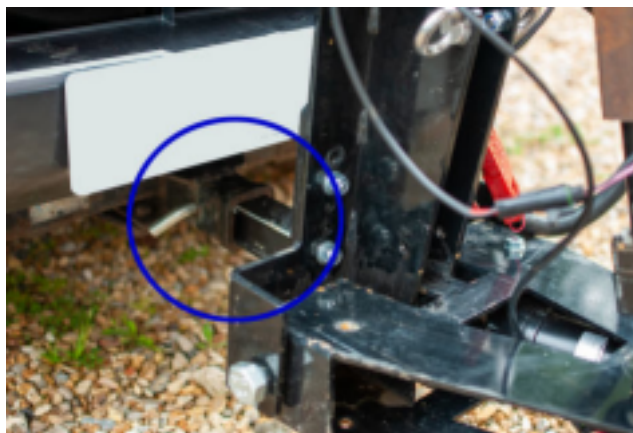

Connect the electrical connectors from the plough to the corresponding connectors on the vehicle.

Raise the plough off the ground with the use of the controller. Adjust all caster wheels to their fully raised positions.

The Plough is now ready for use.

4.3 Removal of snow plough from vehicle

Ensure that vehicle and plough are on a flat smooth surface

Raise the plough up to enable the caster wheel to be adjusted to the “down” position.

Once the caster wheels on the blade are lowered, lower the plough back to the ground. Ensure that the top ram bolt is part the way up the slider (this ensures that no plough weight is left on the headstock).

Unplug the electrical connections

Take out the safety locking pin

Take the weight of the headstock and roll the plough away from the vehicle.

4.4 Adjustments on the snow blade

Tightening springs, the spring tension for the “spring back” of the blade can be adjusted to prevent the blade pivoting too easily. To do this undo the locking nut of the adjuster and then tighten the lock nut down putting more tension on the spring. Ensure that all springs are tensioned the same amounts.



Caster wheel adjustment, the castor wheels can be raised and lowered by twisting the top adjuster to aid with fitting and removal of the plough from the vehicle.



Spigot height adjustment, the 50mm spigot can be bolted to the headstock in numerous positions. This helps to keep the plough at the correct height off the ground depending on chassis height and blade wear. This can best be done with the plough removed from the vehicle. Remove the four securing bolts from the spigot and replace them in the holes that best line up when the spigot is set at the correct height to the headstock.

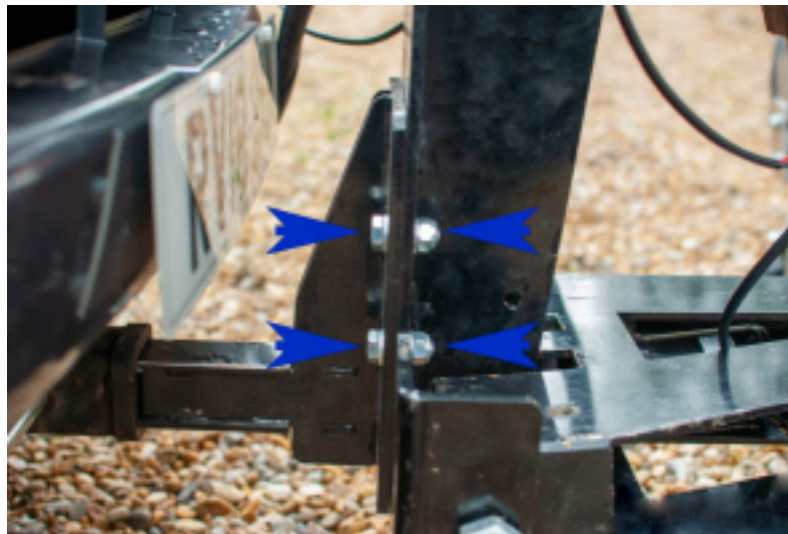

5 Operation

5.1 Operation



Attention!

Danger of crushing due to the blade flipping back.

Never reach into the swing area of the blade when it is tilted forward and the pullback springs are tensioned Drive in reverse until the blade again rests on the stop buffers!

Lifting and Lowering the plough

1. Using the winch controller press the lift or lower button to raise and lower the plough.

Angling the Blade

1. Pull out the pin to allow the plough to angle left-right. Angle to the desired place, replace the pin to lock the blade into position

6. Maintenance

Regular cleaning is essential to the longevity of the plough. Do not use high pressure water to clean the electronic control box or lift/angling rams. Replace any grease/lubricant that is removed during the cleaning process.

Fuses within control box, FH1 10amp headlight fuse, FH2 10a headlight fuse, FH3 40a lowering fuse, FH4 40a angling fuse, FH5 40a lift fuse, FH6 40a lift fuse

Urethane edges must be replaced when any part of the blade has a protrusion of 15mm or less. To remove, undo one of the end plates on the plough blade by removing 4 securing bolts, slide the urethane edge out of its slot. Slide in a new urethane edge. Replace end plate with 4 securing bolts (do not tighten these bolts over 30NM).

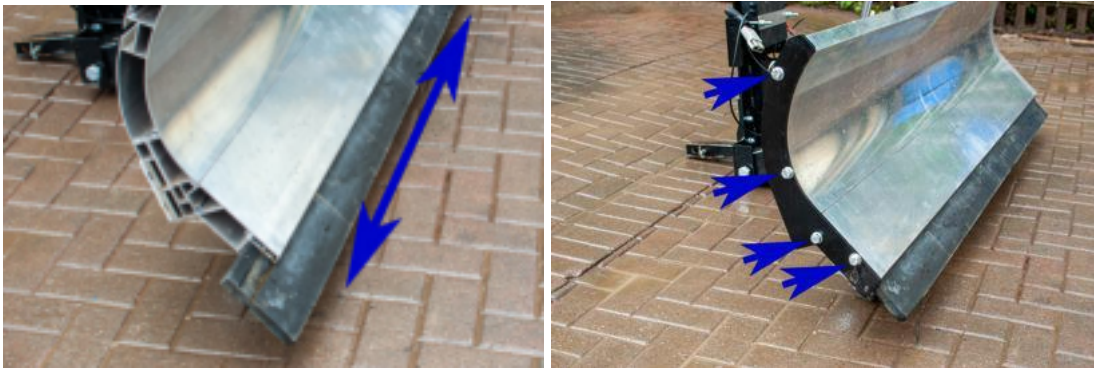

Pre and post season, grease all pivot bars and bolts

Out of season storage, grease any chrome areas that are showing on rams to prevent corrosion.

Store in cool, dry place

7. Electrical Connections (For UTV with **Electric Lift and Lower**)

Please refer to the diagram for electrical connections.

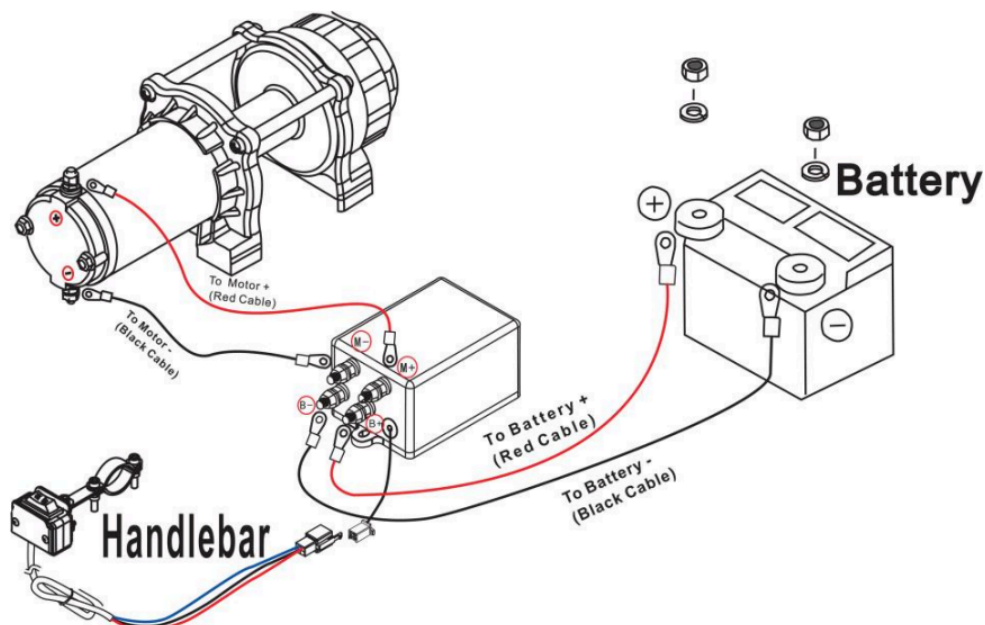

8. Troubleshooting

Problem	Cause
Plough does not respond to joystick operation	<ol style="list-style-type: none">1. Controller connection not fully connected2. Battery connection not fully connected3. Battery has no/limited power4. On/off switch in off position
Plough does not lift or lower	<ol style="list-style-type: none">1. Ram connection disconnected2. Fuse blown in control box
Plough does not angle	<ol style="list-style-type: none">1. Ram connection disconnected2. Fuse blown in control box
Plough does not or struggles to float	<ol style="list-style-type: none">1. Bolt on top end of ram is done up too tight on the slotted shaft

9. Blade parts diagram

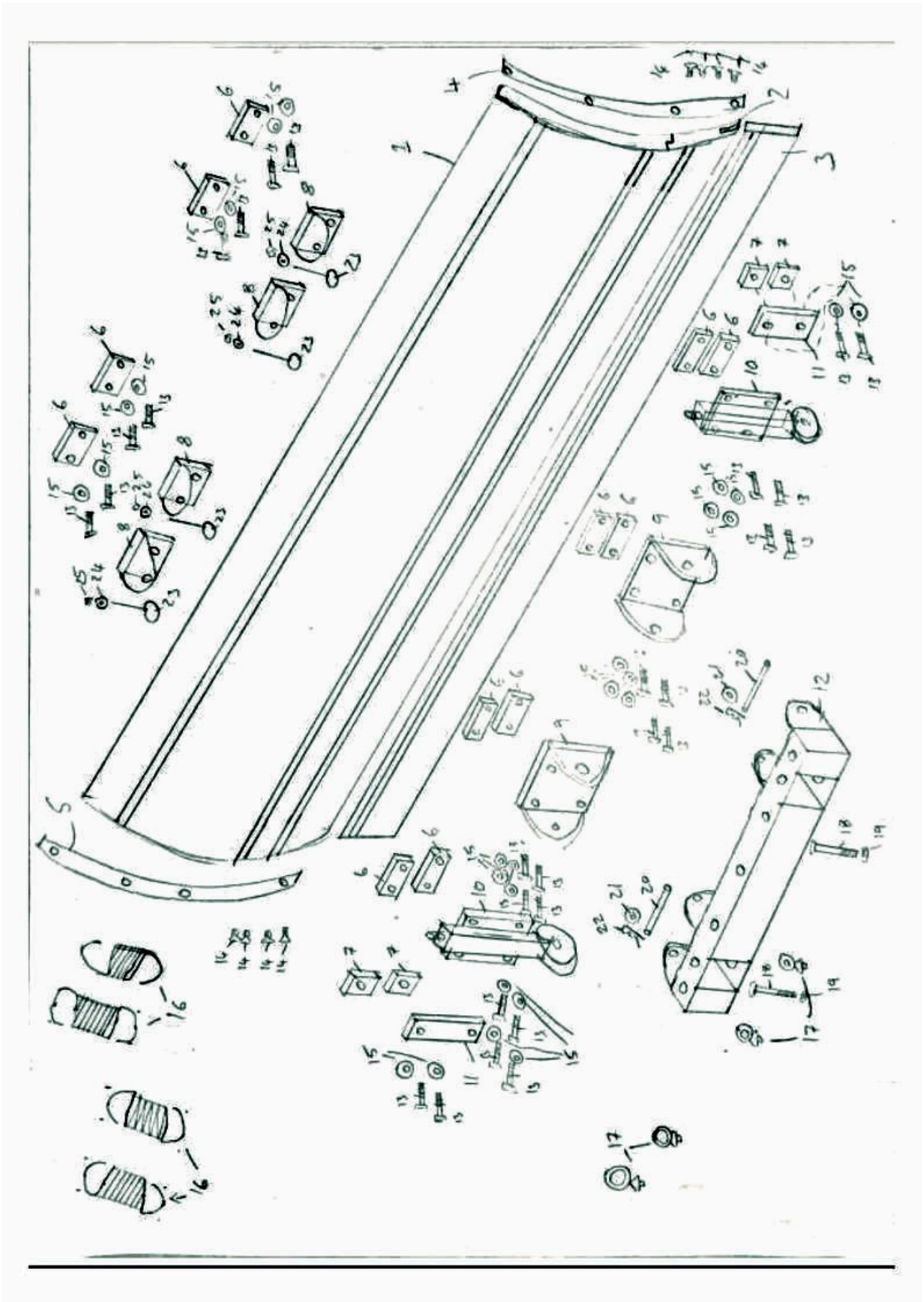

No.	Description	Part Number	Quantity
1	Plough Blade Upper	700207	1
2	Plough Blade Lower	700208	1
3	1.5m Urethane Cutting Edge	700227	1
4	R/H End Plate	700211	1
5	L/H End Plate	700211	1
6	Double bolt mounting plate	700213	12
7	Single bolt mounting plate	700214	4
8	Double bolt spring mounting plate	700215	4
9	Pivot mounting bracket	700216	2
10	Jockey wheel assembly	700217	2
11	Double bolt fixing plate	700218	2
12	Push bar	700219	1
13	Fixing bolt	BOLTM12X30	28
14	End plate fixing bolt	BOLTM12X25CS	8
15	Washer	M12FLATWASHER	28
16	Spring	700220	4
17	Spring fixing ring short	700221	4
18	Fixing Bolt	Bolt ½ inch x 2 ½ inch	1
19	Fixing Nut	Nut ½ inch	1
20	Pivot Pin Bolt	Bolt M20 x 200mm	2
21	Washer	WasherflatM20	8
22	Pivot pin nut	NutM20	2
23	Spring fixing ring long	700223	4
24	Washer	WasherflatM12ss	4
25	Nut	NutM12ss	4

10. Technical data

10.1 Technical data

Overall Blade Height	620 mm
Overall Blade Length	1525 mm
Weight	90kg (weight applied to front axle when plough is fitted is vehicle dependant)
Material	6063T6 Aluminium Extruded Blade BSEN 755-9 Mill Finish
Angle	65 Degree Attack Angle

Declaration of Conformity

EC Declaration of Conformity



Kersten (UK) Ltd

Progress House
39 Boulton Road
Reading
RG2 0NH

Declares under our sole responsibility that the product

FB-UTV-1.5m-Plough

Conforms with the harmonised standards of
2006/95/EC Low Voltage Directive
2006/42/EC Machinery Directive

Year of UKCA and CE marking 2022

Signed;

Douglas Faulkner
Operations Manager
Kersten (UK) Ltd

A handwritten signature in black ink that reads 'Douglas Faulkner'.